

Undergraduate Engineers Engaging and Reflecting in a Professional Practice Simulation

Funded by a grant from the NSF Course, Curriculum, and Laboratory Improvement (CCLI) program (DUE-0919347), we have developed *Nephrotex*, a virtual simulation of authentic engineering practice designed to increase the persistence of engineering undergraduates in pursuit of degree attainment. In this simulation game, students take on the role of an intern in a fictitious company and design new ultrafiltration membranes for kidney dialysis machines.

Nephrotex supplies first-year engineering undergraduates with a more complete and accurate understanding of the engineering profession. The game is tailored to the newest generation of engineering students who are more computer literate, electronically connected, and simulation game-oriented than any prior generation. The game also is *epistemic frame-based* in that it seeks to teach and assess the degree to which students acquire the skills, knowledge, values, identity, and epistemology (i.e., the epistemic frame) of the engineering profession.

Prior work has shown that a key step in developing the epistemic frame of many professions, especially those that require innovation, is some form of *professional practicum*^{1,2}, which is an environment in which a learner takes professional action in a supervised setting and then reflects on the results with peers and mentors. Skills and knowledge become more and more closely tied as the student learns to see the world using the epistemic frame of the profession. Examples include capstone design courses in undergraduate engineering programs, medical internships and residencies, or almost any graduate program in STEM disciplines. Prior work has also shown that *epistemic games*—learning environments where students game-play to develop the epistemic frame of a profession—increases students’ understanding of and interest in the profession³⁻⁵.

In this paper, we present a detailed description of the virtual internship, the important role of the design advisors/mentors in the simulation, and preliminary results of the first semester of *Nephrotex*. Our results show the potential of this novel epistemic game in which undergraduate engineering students role-play as professional engineers-in-training in order to develop the skills, knowledge, values, identity, and epistemology of engineers.

The Epistemic Game: Nephrotex

In *Nephrotex*, students become interns in the fictitious company Nephrotex, whose core technology is the ultrafiltration unit, or dialyzer, of a hemodialysis machine. The students’ task is to design a next-generation dialyzer membrane that incorporates carbon nanotubes and chemical surfactants.

Nephrotex Goals and Tasks

To redesign the dialyzer unit, four aspects of the hollow fiber material can be altered (see Figure 1): the base polymer, percent carbon nanotubes, material processing method, and surfactant. If students choose to test a combination of these parameters, their choices serve as the input to a “black box” that yields the following outputs or performance characteristics: biocompatibility, marketability, reliability, ultrafiltration rate, and cost.

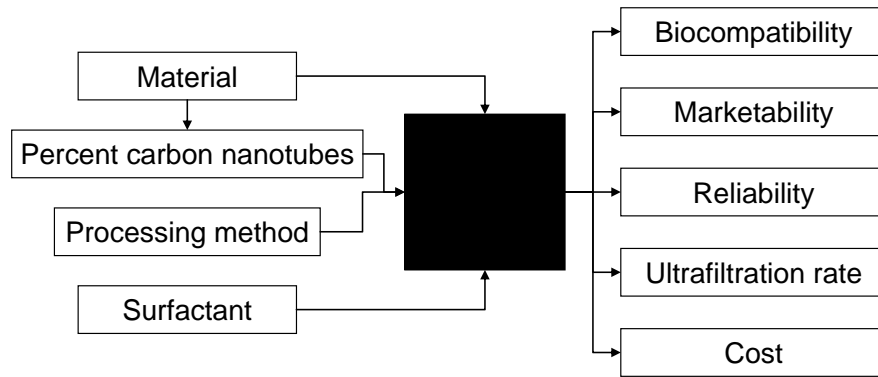

Figure 1. Nephrotex inputs and outputs for virtual design. The “black box” represents the physical principles and assumed relationships that govern hemodialysis ultrafiltration.

To accomplish this goal, students work with a collection of human and virtual *nonplayer characters*: that is, with real people playing the role of mentors and supervisors in the virtual internship, as well as computer-generated characters who play the roles of company president, head of research and development, and internal consultants. The virtual internship requires a total of three human non-player characters, two *design advisors* who serve as mentors and interact with players using instant messaging and email, and an *internship coordinator*, who interacts with players in person and is responsible for monitoring professionalism of the players during class time and troubleshooting the performance of the game software.

The design advisors thus have to be online during every class period and check in frequently between classes. These mentors need to be able to answer the content and game-related questions of the students, understand how the virtual internship system works and help troubleshoot it, guide students in reflection discussions, and at all times maintain a professional tone and role in the virtual internship. In the implementations this past fall, the design advisors were undergraduate teaching assistants; the internship coordinator was the professor for the course, although her area of professional expertise was not biomedical engineering.

Students work in small groups and are guided by their design advisor, with whom they interact using an e-mail and Internet chat system built into the simulation. Teams proceed through design-build-test cycles, first with just one material and subsequently with all materials, including all possible values of all input parameters (see Figure 2). They receive feedback on designs from virtual nonplayer characters with an interest in the project—a clinical engineer, a manufacturing engineer, a focus group liaison, and representatives from marketing and product support—all of whom are programmed to evaluate students’ design choices. At the end of each design phase, students make a recommendation and justify their choice based on how it satisfies the competing demands of these stakeholders. One key element of the virtual internship is that there is no optimal solution—that is, no solution that both minimizes cost and maximizes the other performance criteria. The students must find a solution that they believe is optimal given the constraints of the problem, and then defend that choice in a formal presentation.

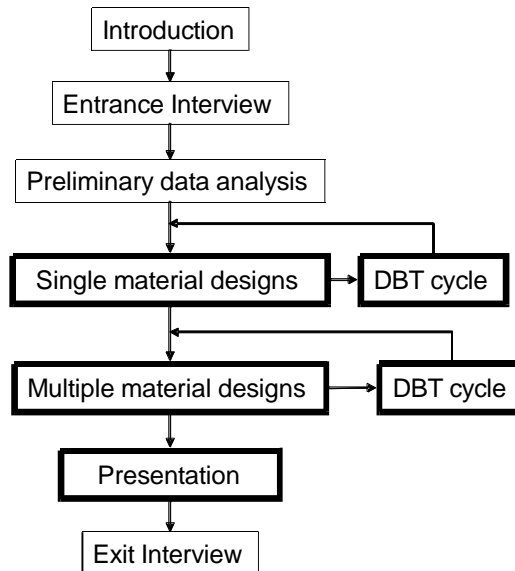

Figure 2. Nephrotex work flow diagram. Light borders around boxes indicate individual work; heavy borders indicate teamwork. DBT = design-build-test cycle.

Furthermore, to assist in the implementation in a first-year introductory engineering course, the game includes elements common to many first year engineering courses, such as literature searching and citation, different engineering disciplines, poster and podium presentations, engineering ethics, and teamwork. But it does so in the context of a simulation of real engineering processes and practices. As such, it covers important supplementary topics that often are not covered in introductory courses such as keeping a design notebook, time management, and interacting professionally with clients and employers.

Game Mechanics

Game play is conducted in a computer simulation of the Nephrotex professional office. The simulation follows the workflow of an introductory engineering design course in which students work in design teams with a design advisor and meet with real clients to develop and propose a solution to a real design problem. Game play takes place face-to-face during class time, but students are able to access the simulation outside of class as well. Students engage in in-class and out-of-class small-group and individual activities (e.g., keeping an electronic notebook). The activities focus students on developing engineering *skills* (e.g., graphical, written, and oral communication; literature search and interpretation; teamwork), *knowledge* (e.g., basic manufacturing, nanotechnology, tradeoffs in design), *identity* (promoted through interaction with clients), *values* (e.g., by attempting to meet the conflicting demands of various stakeholders), and *epistemology* (by making decisions in all of the above contexts).

The game is organized into a series of activities, or “rooms,” each with a specific set of resources and a specific work product students send to the nonplayer characters via email (see Table 1). Within each room, students converse with each other and with nonplayer characters (both real and virtual) via Internet chat. All of this activity is recorded by the game system, yielding data that can be used to model students’ developing epistemic frames.

Table 1***Sequence of Activities and Work Products Associated With Each Nephrotex Room***

Day	Room	Time (min.)	Title	Exit product/request
1	1	30	Entrance interview	Interview completion confirmation
	2	15	Staff page creation	Link to complete staff page
	3	Homework	Dialysis research	Reading summary notebook entry
2	4	45	Summary of research data	R&D results including graphs
3	5	30	Internal consultant feedback	Summary of feedback implications
	6	15	Assignment of literature duties	Email with research roles
	7	Homework	Documentation of literature search	Literature search notes
4	8	30	Discussion ranking attributes	Ranked attribute list
	9	15	Design alternatives: Five prototypes	Justification for tests
5	10	45	Decision on top five designs	Team experimental device request
	11	Homework	Results from prototype tests	Graph of experimental results
6	12	30	Five new prototypes	Justification for tests
	13	15	Justifications discussion	Summary of team discussion
	14	Homework	Integration and implementation	Implementation proposal
7	15	15	Results of new prototypes	Graph and description of results
	16	30	Final design selection	Justified selection for best design
	17	Homework	Preparation of presentation	Presentation draft
8	18	45	Presentation	Poster or PowerPoint
9	19	45	Critique	Feedback to other groups
10	20	45	Exit interview	Completed exit interview

Each room (activity) in the game is also associated with a specific set of frame elements that are identified in advance during game development in a *frameboard*. The frameboard specifies the kinds of feedback nonplayer characters will provide to students during the game, but it also serves as a hypothesis about the kinds of engineering thinking that will develop in each game activity.

Intake and exit interviews provide a robust, mixed-method approach to determining (a) whether and how *Nephrotex* affects students' motivation to pursue training as an engineer and (b) how epistemic frame development progresses over time. Data are collected during these interviews through:

1. An *epistemic frame inventory*, to assess the extent to which players have developed the skills, knowledge, values, sense of identity, and epistemology (the epistemic frame) of the engineering profession⁶⁻⁹;

2. An *engineering intentions instrument*, including items from the *Test of Science Related Attitudes* to assess the extent to which players intend to pursue further study of engineering and/or an engineering career¹⁰; and
3. A *game immersion instrument*, to assess students' qualitative experiences with the game activities, their interest in the game overall, their understanding of the engineering profession, and their career intentions.

Epistemic Mentoring

There are three key areas in the simulation in which the mentors have an important role. First, mentors need to enforce the professional tone and fiction of the internship and appropriately answer questions that the students have. Second, they need to be proficient in using the online simulation software and manage the game experience for the students. Third, and perhaps most importantly, they lead reflection discussions at various times in the simulation to help students think metacognitively about the internship.

The Mentor Role

Mentors need to embody a professional role while acting as design advisors in *Nephrotex*. Many mentors come to the simulation with years of teaching experience (or years of experience as a traditional student), and it is difficult for them to switch to a mentor role. Much like an engineering design advisor, the mentor role is more of a “virtual internship manager” than that of a traditional teacher. The design advisor/mentor manages the experience of the students and leads them through the design process without providing solutions or “correct” answers. These advisor-mentors give students feedback and demonstrate what a professional does by personifying that professional (an engineer in the case of *Nephrotex*). Defining, practicing, and perfecting this mentor role is the majority of what the training of epistemic mentors focuses on.

Mentors spend a lot of time in the virtual internship checking in on students' progress, asking questions to make sure they understand what they are doing, and directing students to the appropriate resources in the virtual internship simulation when they have a question. Some typical mentor dialogue includes: “How is the discussion going? Any problems?,” “I hope the ranking of the attributes is going smoothly. Check your inbox for a new message from Alex,” and “Check the resource section and there is a paper called Carbon nanotube overview.”

Managing the Simulation

Mentors must also be adept at using the virtual internship software in order to move students along in the virtual internship on the appropriate timeline. The virtual internship software helps the mentors assess student work and manage discussions, and gives the mentors pointers and advice on how to respond to student questions. There are scripts for the mentors to follow, but not everything that happens during a typical student/mentor discussion follows the script and mentors need to be able to appropriately improvise while keeping in mind the overall goals of the discussion and practical concerns such as time and workload management.

Leading Reflection Meetings

The reflection meetings that mentors lead at various points in the game are very important to meeting the overall goals of the virtual internship. These meetings give students an opportunity to reflect on the actions of the last room or rooms, think about the implications of those actions,

and look forward to what might be happening next in their internship. Mentors have a set of target epistemic elements (the skills, knowledge, identity, values, and epistemology of engineering design) and use these reflection meetings to help students focus on how they are starting to embody these aspects of engineering in the internship. The questions are fairly open-ended and the mentors guide students into talking about the important elements. Mentors then revoice the targeted epistemic elements after students say them, thus reinforcing their importance. Table 2 presents an example of an exchange between a mentor and some students during a reflection meeting.

Table 2
Example Reflection Meeting

Mentor	Player 1, how will you justify your final prototype in your engineering notebook?
Player 1	Our final prototype provides the best overall care for the patient and that's the most important part of the device, it has a reliability, flux rate, and biocomp of 7, 19, and 32.2 respectively.
Mentor	How did that compare with other prototypes?
Player 2	It had the best biocompatibility, second best flux, second best marketability too.
Player 1	yeah, the marketability is the only real downside to it.
Player 2	The reliability was lower but it still exceeded what the internal consultants wanted.
Player 3	The price was also a bit higher than what a couple of the consultants requested, but it gives the best price without sacrificing performance.
Mentor	So you made your decision based on satisfying as many internal consultants as possible.
Player 2	Yes, mainly it was their concerns we needed to match along with legal requirements.

During these meetings, mentors try to prompt students to justify their decisions about their virtual devices and promote an interesting discussion about those decisions among the team members. Also, as shown in Table 2, they end each section of the reflection meeting with a revoicing of the key aspects of engineering that the meeting was designed to address, sometimes using that opportunity to give an appropriate name to a concept or idea that students had been discussing.

Preliminary Results from Nephrotex

Our work with current CCLI funding has focused on development of the game content (the simulation kernel described above) and on implementation within an introductory first-year engineering course at a large Midwestern public university. In fall 2010, 45 students participated in the module, in two groups, each group working on *Nephrotex* for half of the semester.

Students participated in the internship during a 1-hour class period once or twice a week for a total of 10 hours. The class sessions were held in a computer lab where each student worked at his or her own computer. Some students met virtually through the chat program or in person

outside of class to finish assignments or plan for upcoming tasks. Most of the students self-identified as prospective biomedical engineering majors.

Preliminary results include the pre- and post-interviews that students completed on the first and last days of their virtual internship. These interviews took the form of short-answer survey questions completed online.

Our preliminary results with *Nephrotex* suggest that:

- Students made engineering content learning gains from the pre to the post interview.
- Students were able to solve engineering design problems better during the post interview.
- Most students enjoyed the internship experience and many felt that it reinforced their intentions to major in engineering.
- *Nephrotex* gave students a more realistic understanding of what engineers actually do.
- Students were engaged in the simulation and were invested in the outcomes of their virtual projects.

Engineering Learning Gains

As part of the virtual internship, students independently research kidney functions, performance of dialysis machines, principles of transport phenomena, carbon nanotube functionality, effects of surfactant coatings, and filtration material specifications. As the virtual internship progresses, students are required to complete a review of relevant literature and cite all internal and external sources. As a result, they show increased understanding of these aspects of engineering. For example, Figure 3 shows student responses to an open-ended question about the mechanisms by which carbon nanotubes increase the reliability of polymeric membranes. One third of students during the pre-interview did not know enough to answer the question, while during the post-interview, all of the students gave at least one of the two correct responses (either that carbon nanotubes increase the strength or rigidity of the membrane or that carbon nanotubes increase the flux).

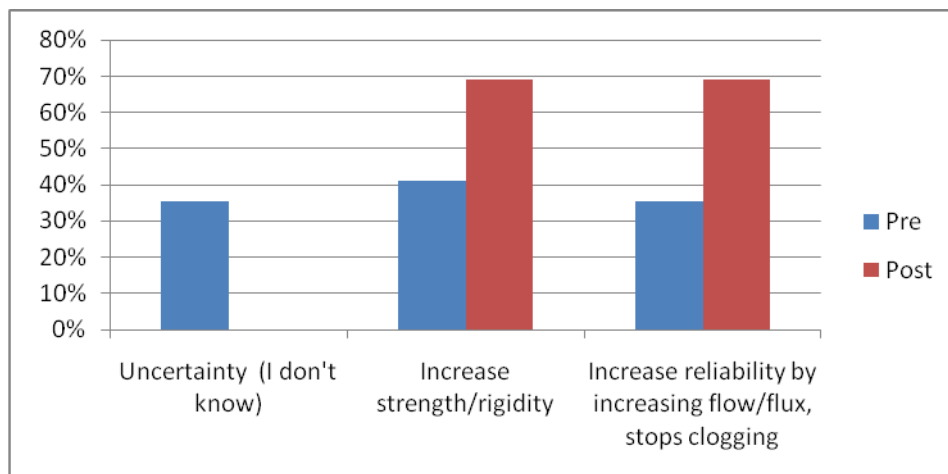

Figure 3. Responses to the question “How do carbon nanotubes increase the reliability of polymeric membranes?”

Similarly, Figure 4 shows the pre- and post-responses to a multiple choice question on strategies to prevent membrane fouling. Seventy percent of the students chose the correct answer (Add a charge to the membrane) on the posttest, compared to 15% on the pretest.

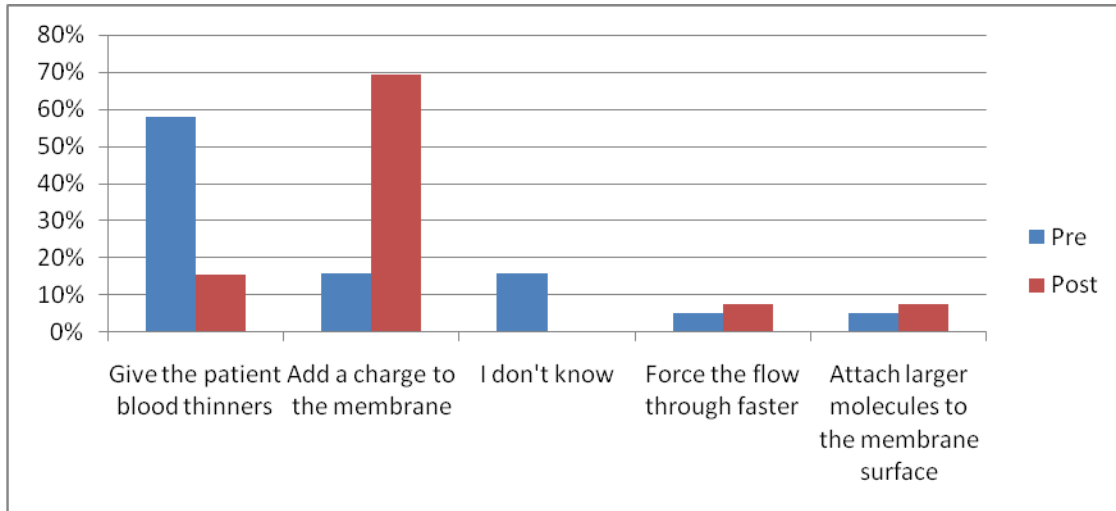

Figure 4. Responses to the question about strategies to prevent membrane fouling.

Impact on Performance

Students performed significantly better at designing a bioengineering experiment after playing *Nephrotex*. Before the game, 16% of students were able to design an appropriate experiment to test the properties of a biomaterial. After the game, 58% were able to do so ($p < .001$). The effect size of this change was 1.1. For comparison, a rise in one letter grade on average in a typical course is an effect size of 0.6.

The substantive change in students' responses was more striking. For each student, we looked to see how their responses changed from pre- to post-game interview. Figure 5 shows one student's responses to matched questions on engineering experimental design.

Response before the game:

I will take a few samples of the ultrafiltration membrane and test a few of the surfactants on them. I would then record my observations and results.

Response after the game:

An experimental setup that will allow you to determine the effects of carbon nanotubes on membrane fouling is by making a mock filtration system. Different concentrations of nanotubes can be used in the membrane. A fouling substance can be made out of vegetable soup and used to test the different contents of the carbon nanotubes. Data can be collected on the percent of nanotubes and the flux rate produced by each content of carbon nanotubes. Data can also be collected on the reliability rate of the membrane's performance. To interpret this data, you can examine the percentage of carbon nanotubes that produces the highest flux and

filtration rate. You can also analyze which percent of carbon nanotubes possess the greatest reliability.

Figure 5. One student's pre- and post-game responses to a question on engineering experimental design.

Other Results

Our preliminary analyses also showed that after *Nephrotex* 71% of students reported that they were committed to pursuing engineering as a career choice, 56% reported a better understanding of engineering, and that students were engaged in the virtual internship, especially with respect to wanting to find out about the results of their virtual device. These results are reported in more detail in Chesler et al.'s conference paper¹¹.

Discussion and Future Work

Our results presented are preliminary and future work includes coding the vast amounts of data collected in the simulation for the presence and co-occurrence of the engineering epistemic elements that the mentors helped the students focus on during the internship. We have developed epistemic network analysis (ENA) – based on social network analysis – to help model and visualize this type of data^{12,13}. Future work also includes training more mentors to be design advisors at other institutions so that the simulation can be scaled up and used with many more students around the country.

Although we have only run this simulation with one semester's worth of students, we feel that our preliminary results show that *Nephrotex* has the potential to help students gain a more complete and accurate view of the engineering profession and therefore impact retention rates of undergraduate engineering majors. The simulation also increases content knowledge and gives students an opportunity to practice valuable professional skills that they will need in their later engineering courses and their careers.

Bibliography

1. Schon, D.A., *The reflective practitioner: How professionals think in action*. 1983, New York: Basic Books. x, 374.
2. Schon, D.A., *Educating the reflective practitioner: Toward a new design for teaching and learning in the professions*. 1987, San Francisco: Jossey-Bass.
3. Shaffer, D.W., *How Computer Games Help Children Learn*. 2007, New York: Palgrave.
4. Svarovsky, G.N. and D.W. Shaffer, SodaConstructing knowledge through exploratoids. *Journal of Research in Science Teaching*, 2007. 44(1): p. 133-153.
5. Bagley, E.A.S. and D.W. Shaffer, When people get in the way: Promoting civic thinking through epistemic gameplay. *International Journal of Gaming and Computer-Mediated Simulations*, 2009. 1(1): p. 36-52.
6. Svarovsky, G., *Unpacking the Digital Zoo: An analysis of the learning processes within an engineering epistemic game*, in *Educational Psychology*. 2009, University of Wisconsin–Madison.
7. Kettinger, W.J., J.T.C. Teng, and S. Guha, *Business Process Change: A study of methodologies, techniques, and tools*. *MIS Quarterly*, 1997. 21(1): p. 55–80.
8. Chi, M.T.H., *Quantifying qualitative analyses of verbal data: A practical guide*. *Journal of the Learning Sciences*, 1997. 6(3): p. 271–315.

9. Lave, J. and E. Wenger, *Situated learning: Legitimate peripheral participation*. 1991, Cambridge, MA: Cambridge University Press.
10. Fraser, B., *TOSRA: Test of science related attitudes*, Australian Council for Educational Research, Editor. 1981.
11. Chesler, N.C., D.W. Shaffer, C.M. D'Angelo, and G. Arastoopour. Use of a professional practice simulation in a first year Introduction to Engineering course. ASEE Conference Proceedings, 2011.
12. Shaffer, D.W., et al., *Epistemic Network Analysis: A prototype for 21st century assesement of learning*. The International Journal of Learning and Media, 2009. 1(1): p. 1–21.
13. Rupp, A., et al. *Modeling learning progressions in epistemic games with epistemic network analysis: Principles for data analysis and generation*. in *LeaPS*. 2009. Iowa City, IA.